

Huvudströmbrytare EL-matning  
 1-fas 230 volt 10amp.  
 Brytare 1800 mm över övre plan 200 mm in.

LOAD & FORCES	
	300kg.
$F_h$	2946N
$F_e$	1493N
$F_1$	2219N
$F_h$	5268N

Use 2 M10 in each column on 300 kg lifts.

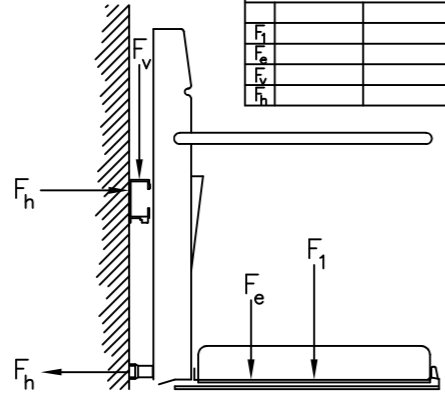
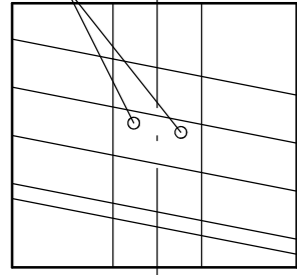

Stanchion Mounted Rail

1. Support stanchions must be fixed to concrete landing and treads, concrete strength assumed to be 30N/mm2
2. Fixings used are M8 ramset 'Dynabolt'.
3. Pull out forces are 3.3kn and push in forces are 4.2kn
4. Exempel: 4737 N x 0.1020 = 483,174 kp

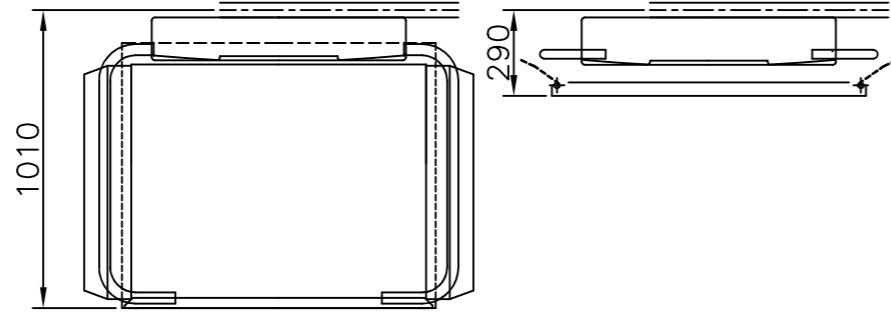
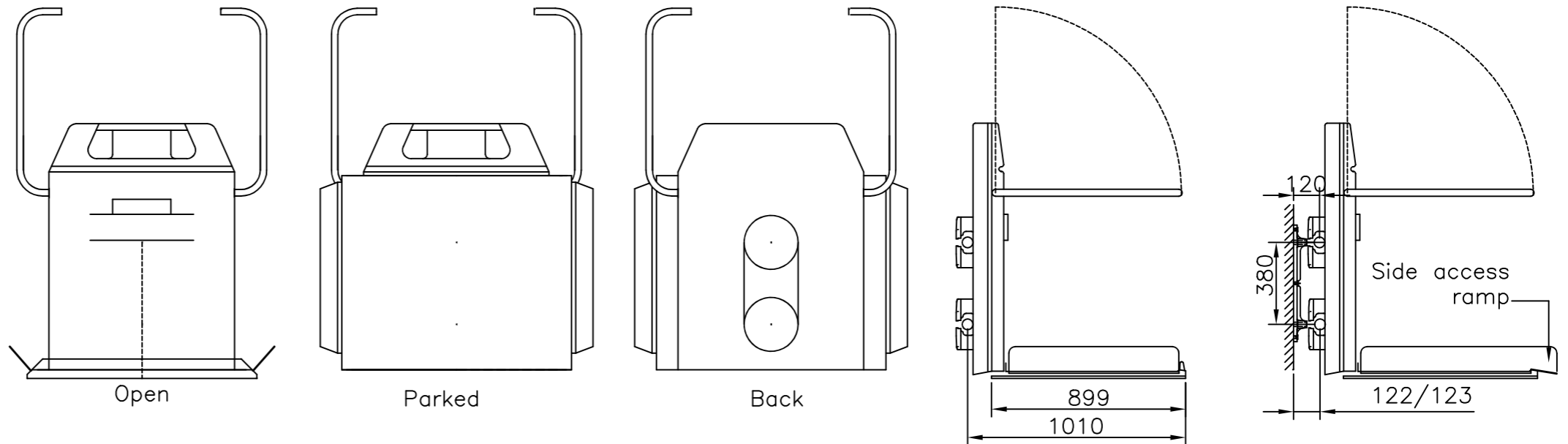

Det.nr	Ant.	Benämning	Referens	Material	Modell nr	Ämnesdim.
Konstr.	Rit.	Kontr.	Stand.	Godk.	Skala	Datum
Konstr	TT	---	---	---	Skala 1:1	231010
Globus TT AB www.globustt.se			Globus Saturnus Namnrad 3			Där ej annat angivits: Tolerans enligt SMS 715
					Överordn. Smst.	Cad program
						2002 LT