

ADJACENT SURFACE DISTANCE BS6440:2011		
GAP BETWEEN THE PLATFORM & ADJACENT WALL (mm)	FULL HEIGHT CONTROLS AND SIGNAGE WALL	PARTIAL HEIGHT WALL WITH PROJECTION OR RECESSES
<10	✓	SENSITIVE EDGE, PHOTO CELL OR LIGHT CURTAIN REQUIRED
>10 - <100	✓	SENSITIVE EDGE, PHOTO CELL OR LIGHT CURTAIN REQUIRED
>100 - <300	✓	SENSITIVE EDGE, PHOTO CELL OR LIGHT CURTAIN REQUIRED
>300	✓	✓

Table A

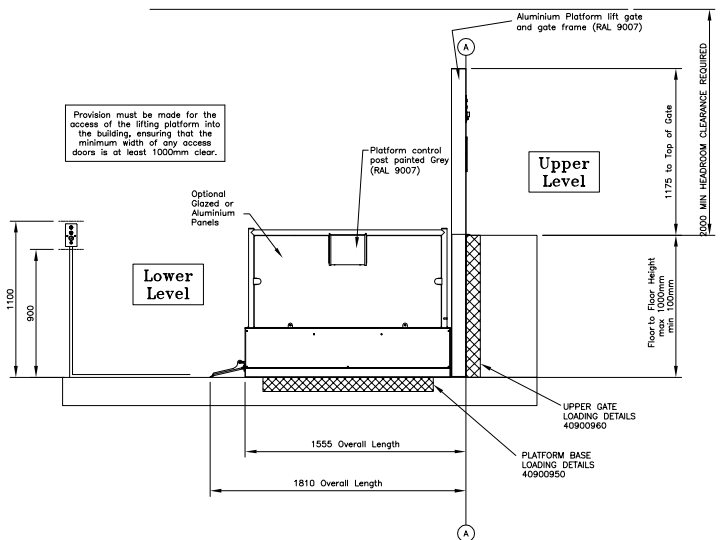
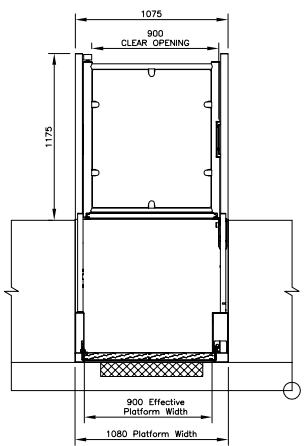
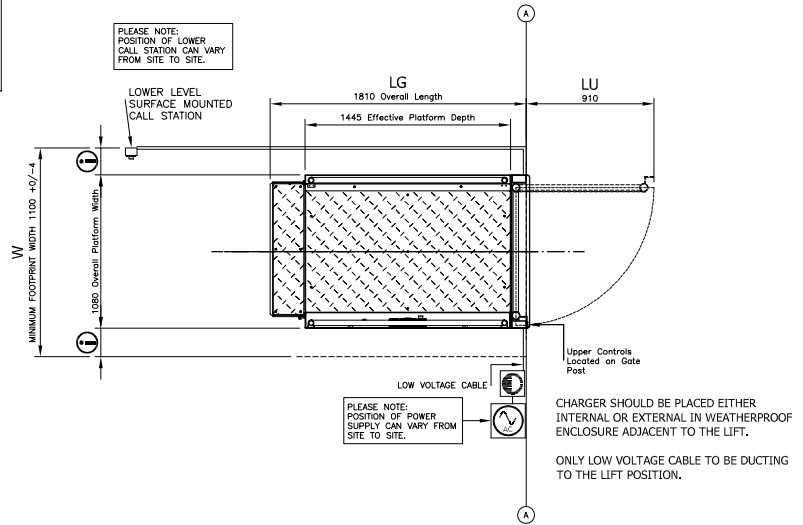

Change History Record			
Issue	CHANGE No.	DATE	INITIALS
A	-----	27/01/14	TL
B	-----	01/07/14	TL

Minimum Footprint Width (W)	1100mm
Minimum Ground Footprint Length (Lg)	1810mm
Minimum Upper Footprint Length (Lu)	910mm

FOR EXTERNAL LIFT POWER SUPPLY NEED TO BE LOCATED INSIDE BUILDING AND DUCTED TO LIFT POSITION

BUILDERS WORK AND GENERAL NOTES – STEP LIFT

The customer is responsible for carrying out the work below. These are required for the lift to comply with the Supply of Machinery (Safety) Regulations 1992. If any points are not clear, please contact Pollocklifts without delay.

- GENERAL
 - Clear access into and through the building for the passage of the lift equipment and personnel must be maintained.
 - Unload delivered materials and store in a suitable dry and secure location within 5m of intended lift site. Parts should be handled with care and slung correctly to avoid damaging components and decorative finishes. Parts may become damaged by storage outside or in damp conditions.
- DIMENSIONS AND TOLERANCES

Do not scale from the drawings. All dimensions are in millimetres except where otherwise stated. All dimensions are to be measured from datum line AA.
- LIFT AREA
 - Floor and side walls in the area where the platform lift is to be located must be firm, smooth level, suitably drained and have no projections or recesses across their face. Any walls surrounding the lift should be positioned as per Table A away from the lift edges in order to eliminate trapping hazards.
 - Make good where necessary around the platform lift and its associated equipment after they are finally positioned and fixed.
- ELECTRICAL WORKS
 - Provide a 230V, 1 phase, 50 hertz, 3 wire permanent supply terminating in a fused spur 13A within close vicinity of the lift (within the fabric of the building + A 20mm Duct installed terminating at lift position as indicated). The switch 5A Charging Circuit must be able to accept 1 x 5A HRC fuse, GEC type "T" or equivalent fuses to BS88 Part 2.
 - For External installation it is recommended that lighting is provided controlled by PIR's.
 - The electrical work must comply with the latest revision of the IEE Wiring Regulations.
 - It is recommended that the supply is protected by a suitable RCD.
 - Where flush / surface mounted call stations are required, walls should be chased out prior to lift installation to allow for mounting of cable conduit and call panels. Client to make good after lift commissioning.

BUILDING WORK REQUIRED

-
-
-
-
-
-

APPROVAL	APPROVED WORKING DRAWING	
	BY:.....	COMP:.....
	SIGNED:.....	DATE:.....

NOTE: THE ABOVE BUILDING WORK MUST BE CARRIED OUT PRIOR TO THE LIFT INSTALLATION

LIFT DATA				
PLATFORM SIZE	900W	THROUGH ACCESS	COLOUR 9007	FLOOR MOUNTED
UPPER GATE HANDED	RH	ALUMINIUM GLAZED	COLOUR 9007	
LOWER GATE HANDED	N/A	-----		
LOWER LEVEL RAMP	ON BOARD RAMP			
TRAVEL	(MIN 100mm MAX 1000mm)mm TBC		

Globus TT AB
Globus Sirius EXTRA

UNIT: STEPLIFT
NAME: CLASSIC 900W RH Upper Gate – On Board Ramp
40900251