

1) This Data Sheet is for planning purposes only. An accurate layout drawing will be provided on receipt of an order.

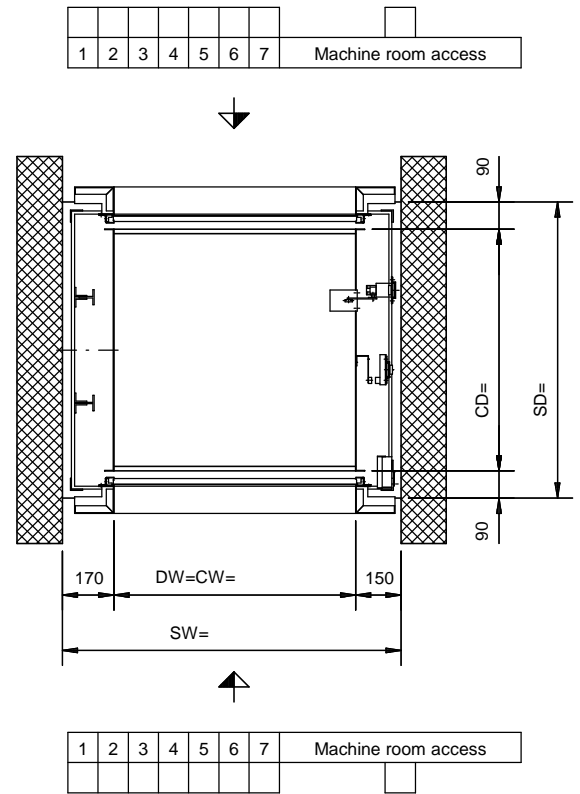
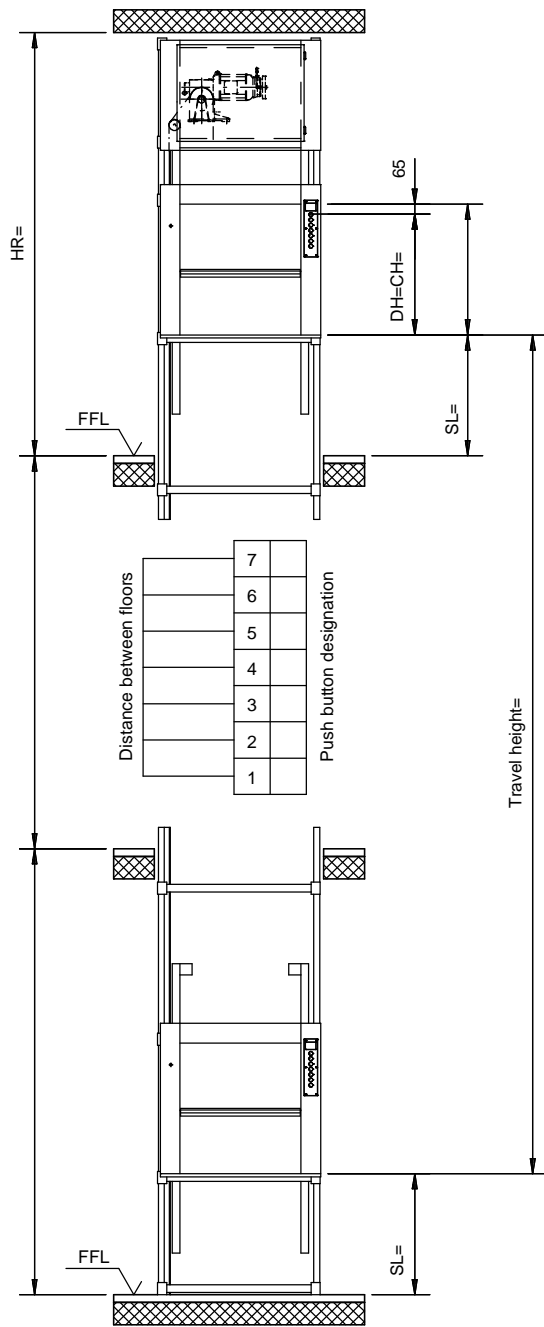

The shaft must be rectangular and perpendicular. Maximum admissible deviation from plumb is +20 mm -0 mm. All dimensions are minimum dimensions.

All dimensions are in mm, and are subject to modification.

Q kg	v m/s	BKG Type	Layout drawing no.	Car dimensions					Headroom HR min. at		Floor distance min.	Sill height SL=min.
				CW= min. max.	CD= min. max.	size alt.	CH= min. max.	size alt.	DH<=800	DH>800		
100	0,30	100.45/0F	5-60010-0008	400 800	400 800	50	600 800	100	SL+DH 1190	2 x DH + 330, same sill height	Sill height at lowest floor =DH/2+130, however min. as all others 700.	
		100.45/1F	5-60110-0005	400 1000	500 1000		600 1200					SL+(1,5 x DH)+790
300	0,20	300.30/14F	5-61410-0004	400 1000	700 1000		800 1200					
Part No.				Edition								
5-60002-0206				04/2015								