

1) This Data Sheet is for planning purposes only. An accurate layout drawing will be provided on receipt of an order.

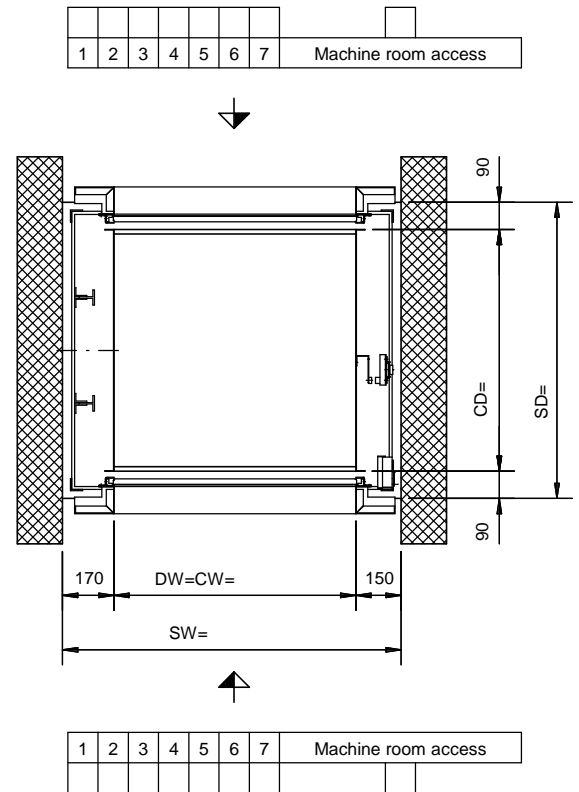
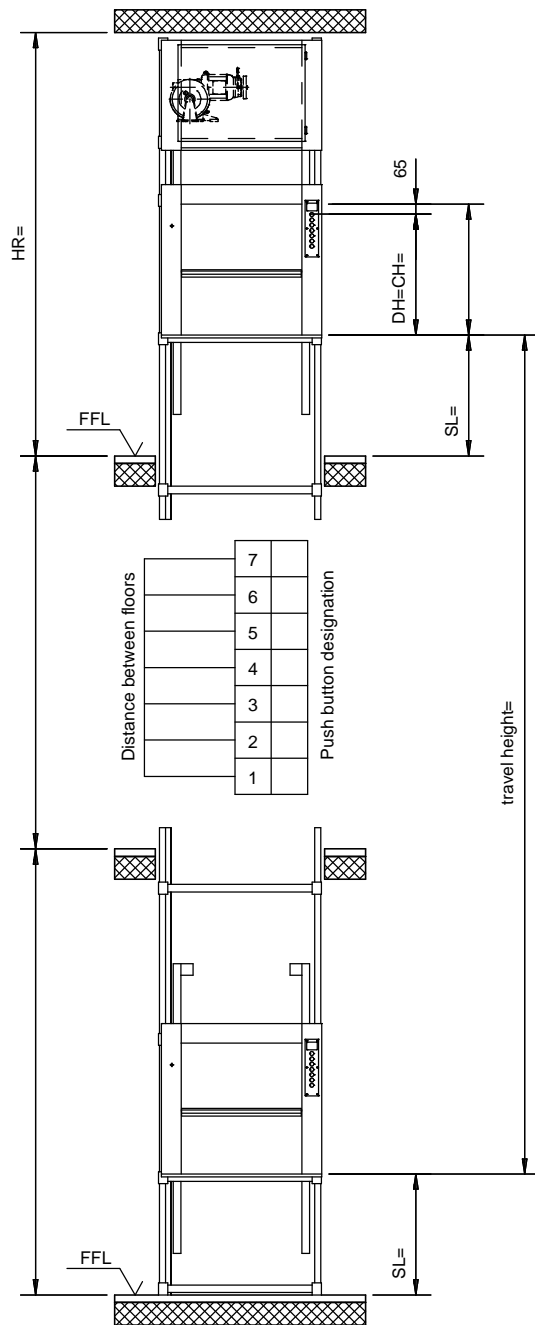

All dimensions are in mm, and are subject to modification.

The shaft must be rectangular and perpendicular. Maximum admissible deviation from plumb is +20 mm -0 mm. All dimensions are minimum dimensions.

Q kg	v m/s	BKG Type	Layout drawing no.	Car dimensions					Headroom HR min. at		Floor distance min.	Sill height SL=min.
				CW= min. max.	CD= min. max.	size alt.	CH= min. max.	size alt.	DH<=800	DH>800		
50	0,45	50.45/0	5-60000-0019	400 600	400 600	50	600 800	100	SL+DH +1190	2 x DH + 330, same sill height	Sill height at lowest floor =DH/2+130, however min. as all others 700.	
100	0,45	100.45/0	5-60000-0020	400 800	400 800		600 800		SL+DH +1190			
		100.45/1	5-60100-0008	400 1000	500 1000		600 1200		SL+DH +1190			SL+(1,5 xDH)+790
		100.45/3	5-60300-0004	350 600	320 350		600 800		SL+DH +1190			SL+(1,5 xDH)+790
300	0,30	300.30/14	5-61400-0006	400 1000	700 1000		800 1200		SL+DH +1300		SL+(1,5 xDH)+790	
				Part No.				Edition				
				5-60002-0205				02/2015				