

1) This Data Sheet is for planning purposes only. An accurate layout drawing will be provided on receipt of an order.

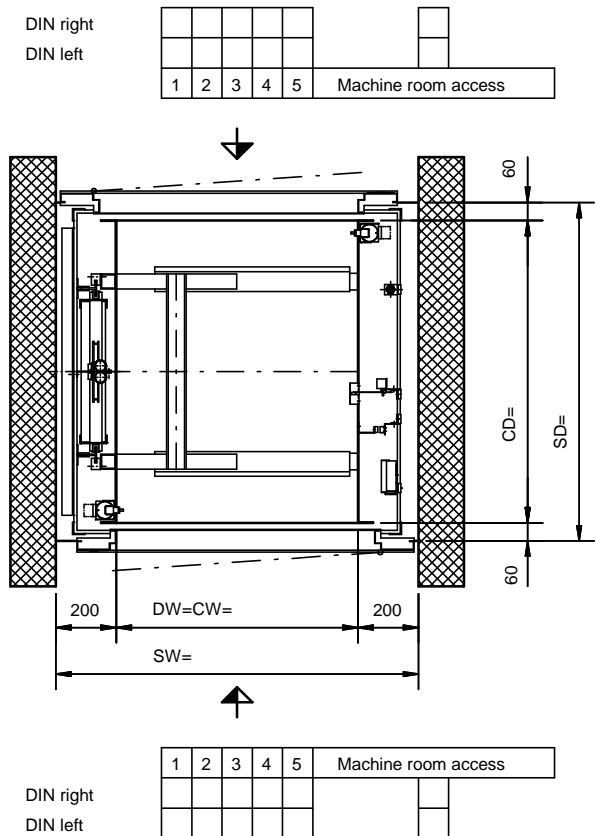
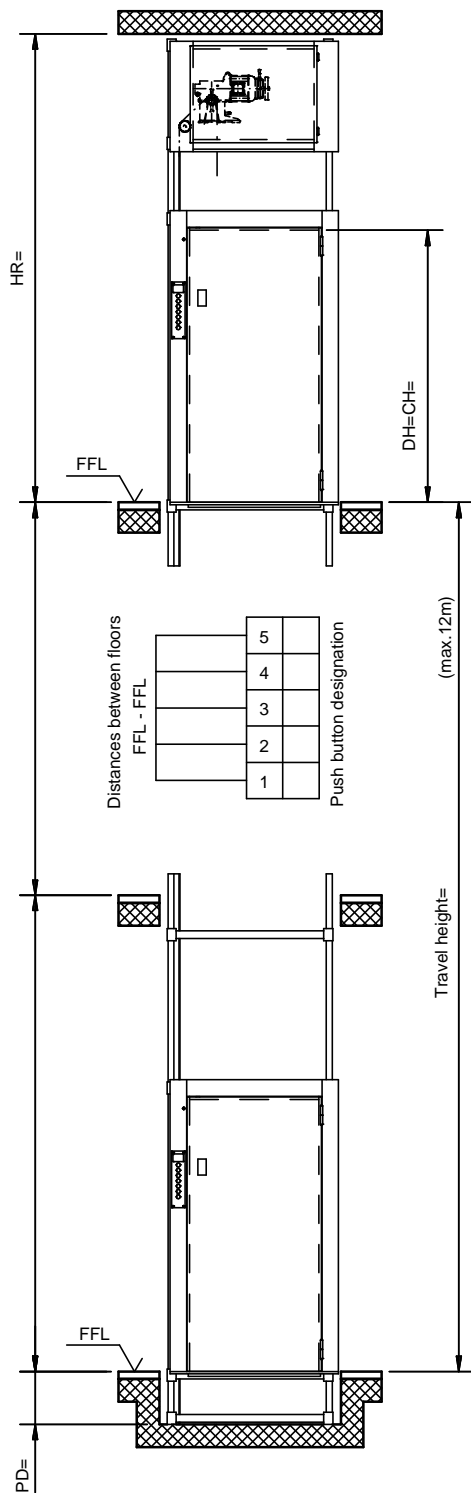

All hinged doors drawn "DIN right"

All dimensions are in mm, and are subject to modification.

The shaft must be rectangular and perpendicular. Maximum admissible deviation from plumb is +20 mm -0 mm. All dimensions are minimum dimensions.

Q	v	BKG	Layout drawing no.	Car dimensions			Headroom HR min. at	Pit depth PD=min.
				CW= min. max.	CD= min. max.	CH= min. max.		
300	0,15	300.15/43F	5-64310-0003	600 1000	800 1000	1300 2000	CH+1350	170
Part No.				Edition				
5-60002-0255				08/2009				