

LIFT WITH BI-PARTING DOORS AT SERVING HEIGHT

Loading:

- at one side
- opposite sides
- adjacent sides

Lift machine positioned:

- above the shaft
- below the shaft
- beside the shaft

Capacity:

- 50 kg
- 100 kg
- 300 kg

Lifting speed:

- $v = 0.20$ m/s
- $v = 0.25$ m/s
- $v = 0.30$ m/s
- $v = 0.45$ m/s

Standard car dimensions:

- min. 300 mm wide, max. 1000 mm wide
- min. 320 mm deep, max. 1000 mm deep
- min. 600 mm high, max. 1200 mm high



LIFT WITH BI-PARTING DOORS AT FLOOR LEVEL

Loading:

- at one side
- opposite sides

Lift machine positioned:

- above the shaft

Capacity:

- 100 kg
- 300 kg

Lifting speed:

- $v = 0.20$ m/s
- $v = 0.30$ m/s

Standard car dimensions:

- min. 400 mm wide, max. 1000 mm wide
- min. 600 mm deep, max. 1000 mm deep
- min. 800 mm high, max. 1200 mm high

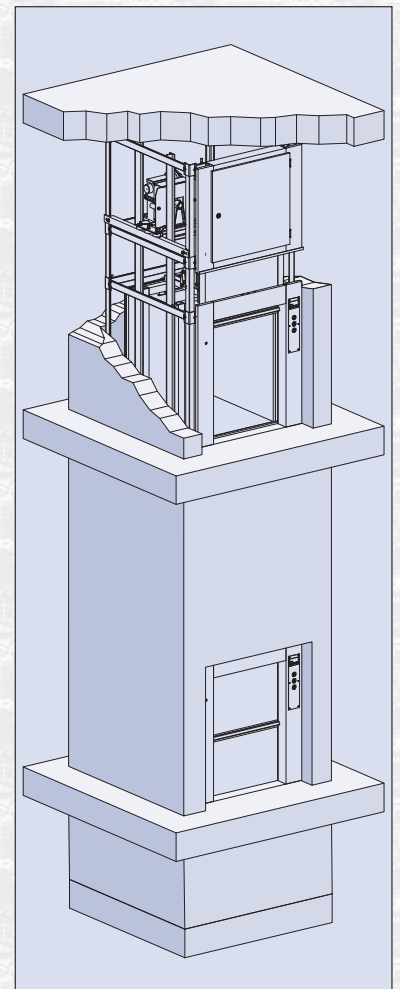



LIFT WITH HINGED DOORS AT FLOOR LEVEL

single or double door

Loading:

- at one side
- opposite sides
- adjacent sides

Lift machine positioned:

- above the shaft
- at the bottom beside the shaft

Capacity:

- 100 kg
- 200 kg
- 300 kg

Lifting speed:

- $v = 0.15 \text{ m/s}$
- $v = 0.20 \text{ m/s}$
- $v = 0.25 \text{ m/s}$
- $v = 0.30 \text{ m/s}$

Standard car dimensions:

- min. 400 mm wide, max. 1000 mm wide
- min. 600 mm deep, max. 1000 mm deep
- min. 800 mm high, max. 1200 mm high

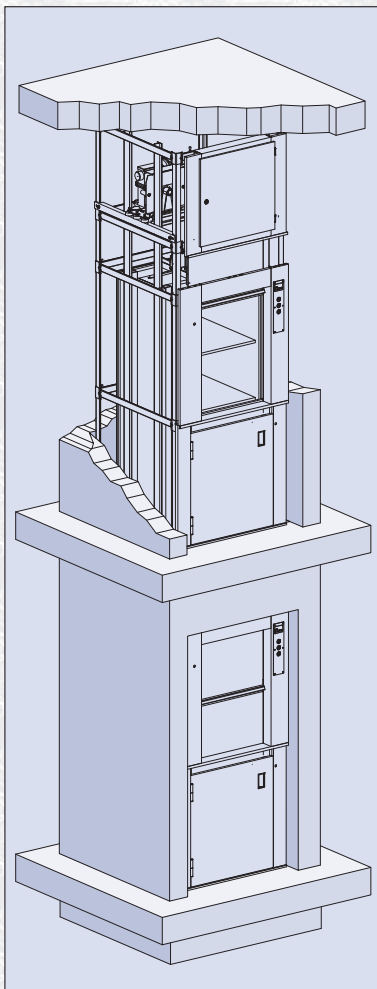
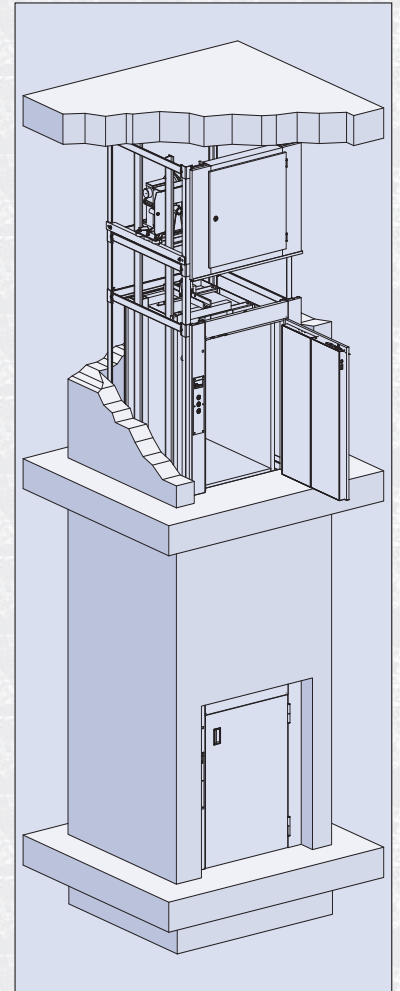

BI-PARTING DOOR/ HINGED DOOR COMBINATION

Loading:

- at one side
- opposite sides

Lift machine positioned:

- above the shaft

Capacity:

- 100 kg
- 300 kg

Lifting speed:

- $v = 0.20 \text{ m/s}$
- $v = 0.30 \text{ m/s}$

Standard car dimensions:

- 550 mm or 600 mm wide
- 700 mm deep
- 1700 mm high



Other variations on request. Subject to alteration.